

Pneumatic Actuator Type 1, Metric Size 400

- Double acting (DA) and Spring Return (SR)
- Single end stop adjustment, open position (DA and SR)
- Option: Single end stop adjustment, closed position (Only DA)

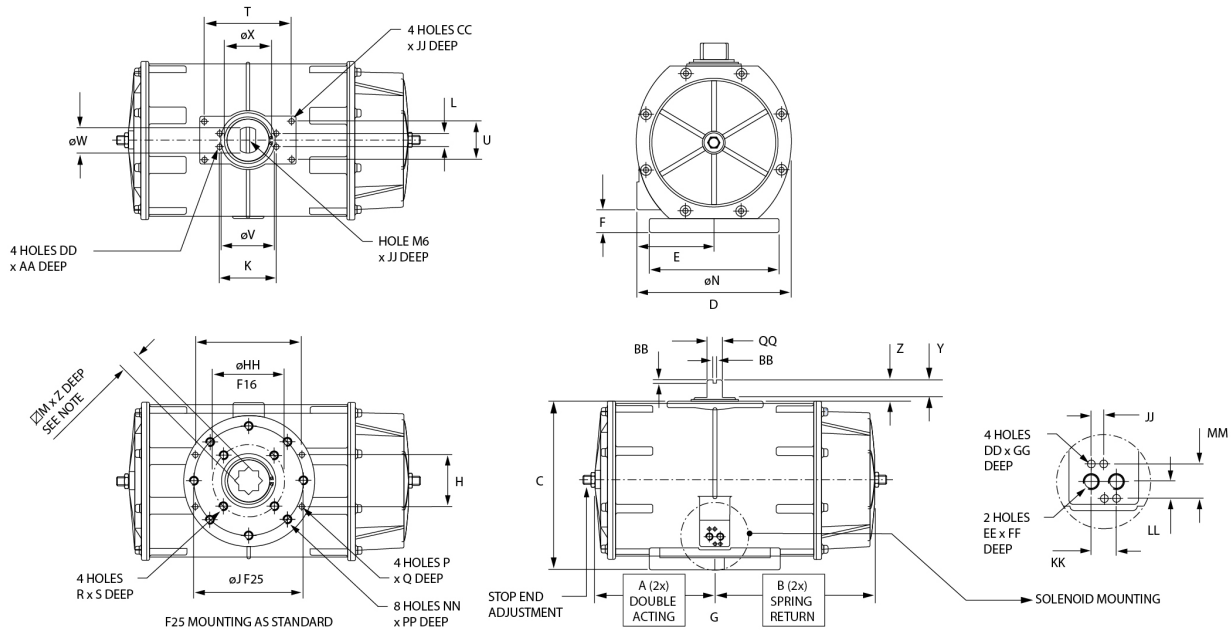

Note! Older versions had different End Caps for Double Acting (DA) and Spring Return Actuators (SR). Later versions are delivered with the type of End Caps specified for SR Actuators, regardless function.

DIMENSIONS, METRIC (mm)

Actuator size	ISO	A	B	C	D	E	F	G	H	ØJ	ØK	L	M	ØN	P	Q	R	S	T	U
WM400	F25/F16	300	371	385	360	180	53	244	117	254	130	30	55	300	M12	22	M20	35	200	90

Actuator size	ISO	ØV	ØW	ØX	Y	Z	AA	BB	CC	DD	EE	FF	GG	ØHH	JJ	KK	LL	MM	NN	PP	QQ
WM400	F25/F16	120	60	111	40	60	9	4	M8	M5	G1/4"	12	8	165	12	24	16	32	M16	25	36

TORQUE

Actuator size	Air Supply	DA Torque	SR Torque (Nm)				
	BAR	Nm	Air - Start	Air - End	Spring - Start	Spring - End	Spring Qty
WM400	6	4803	2915	1891	2912	1888	16

OPERATING DETAILS

Actuator size	Operating time (sec)				Air consumption (litre)		Overall weight (kg)	
	DA Open	DA Close	SR Open	SR Close	Open	Close	DA	SR
WM400	12	12	13	10	13.6	17.5	110.5	135.0